

DP TEM₀₀ Series

Diode Pulse Pumped DP TEM₀₀ Series Q-Switched Lasers

The DP Series offers two configurations, TEM₀₀ and multi-mode, both delivering 2X to 10X higher efficiency and up to 10X the repetition rate of competing products. With repetition rates up to 1kHz and high efficiency reducing heat generation, these lasers enable broader applications and simpler thermal management in air-cooled systems.

The DP TEM₀₀ Series provides up to 50mJ/pulse at 100Hz, 20mJ/pulse at 1kHz, all in TEM₀₀ mode with pulse widths of 6ns to 12ns. Available in IR wavelengths (1064nm/1030nm) and harmonics (GRN, UV, DUV), it offers three cooling options: no-fan, fan-cooled with optional water-cooling, and water- or radiator-cooled, ensuring flexibility for varying thermal requirements.



APPLICATIONS

- Material Processing: Marking, scribing, grooving
- Ion generation, atomic excitation, and quantum physics.
- LCD/LED/OLED panel repair systems.
- LIBS and advanced spectroscopy systems.
- Non-Destructive Testing: Incorporates laser ultrasonics, acoustic microscopy, and photoacoustic.
- Thin Film Technology: Specializes in pulsed laser deposition (PLD).
- OPO Pumping: Supports optical parametric oscillator systems.

FEATURES

- Up to ~50mJ Pulse Energy at 100Hz
- True TEM₀₀ Output
- Short Pulse Widths
- Air-cooled with Radiator Cooled Option
- Robust & Compact Form Factor
- Dynamic **Power Control - PWC**
- Optional Low Jitter operation w/ short-shot energy control [$<1\text{ns}$]
- Power Monitoring and Self-Calibration

Specifications – DP TEM ₀₀ Series							
		DP5	DP20	DP50	DP1k-5	DP1k-10	DP1k-20
Wavelengths [†]		1064nm, 532nm, 355nm, 266nm ¹	1053nm, 527nm, 351nm, 263nm ¹	1030nm, 515nm, 343nm, 257nm ¹	1064nm, 532nm, 355nm, 266nm ¹		
Max Pulse Energy ^{2,4}	IR	2.5mJ*	20mJ	50mJ*	5mJ	10mJ*	20mJ
	GRN	1.5mJ*	10mJ	25mJ*	3mJ	5mJ*	10mJ
	UV	1mJ*	5mJ	15mJ*	2mJ	3mJ*	5mJ*
Average Power	DUV ¹	>0.5 W ¹					
Pulse Width Range ³		~6-10 ns					
Pulse repetition rate		Single shot to 100 Hz			Single shot to 1 kHz		
Pulse-to-pulse stability		<3% rms					
Long-term power stability		<3% rms					
Beam spatial mode ⁵ & M ²		TEM ₀₀ - M ² <1.5					
Beam divergence (nominal)		<2 mrad					
Beam diameter at exit (nominal) ⁵		1 mm – 2.5mm					
Beam roundness		~90%					
Beam pointing stability		<25 μrad					
Polarization ratio (IR) [§]		Vertical; >100:1					
Operational Specifications and Characteristics							
Interface		RS232, Ethernet, Software GUI, External TTL Triggering					
Warm-up time		< 5 minutes from standby, <10 minutes from cold start					
Electrical requirement		15 V DC, 7A	24V DC, 3A	32V DC, 11A			
Line frequency		50-60 Hz					
Power consumption		~10W	~50W	~150W	~50W	~100W	~200W
Dimensions ⁷		11 x 5 x 3.25 in	14 x 6.75 x 4.25in				
Weight		~10 lbs	~15.5 lbs [~7 kg]				
Environmental Requirements							
Ambient temperature		Ambient 15°C to 30°C (59°F to 86°F) Operating Range					
		Relative humidity 0% to 80% max, non-condensing					
Storage conditions		-10°C to 40°C; sea level to 12000 m					
		0% to 80% relative Humidity, non-condensing					
Cooling system		Passively Cooled	Air-Cooled	Water-cooled / Rad-Cooled ⁶			

[1] For DUV 257 nm, 263 nm, or 266 nm outputs, please contact us. [2] Air-cooling or Rad cooling™ systems can be used for laser head heat removal based on pulse energy. [3] Pulse width is model and configuration dependent. [4] Pulse energy efficiency varies with multi-wavelength output options. [5] Values are wavelength and model dependent. [6] Rad cooling™ isolates vibrational noise (low dB) while effectively removing heat. [7] DP Series Lasers are all-in-one (AIO) with back-panel connections for operation and control. [†] For multi-wavelength output options, please contact us. [§] Polarizations vary for blended options. [*] Preliminary specification

Options:

Multi-wavelength	[IR/GRN], [GRN/DUV], [IR/GRN/UV] OR [IR/GRN/UV]	
Blended	All wavelengths come out of single exit port	[MWB]
Blended/Selectable	A single exit port can emit one, two, or three blended wavelengths, selectable via the software GUI.	[MWB/S]
Selectable	Each Individual wavelength is isolated and user-selectable via the software GUI	[MWS]
Format	DP - [Model] - [Power Level] - [xxx]	

Dimensional Drawings

DP5

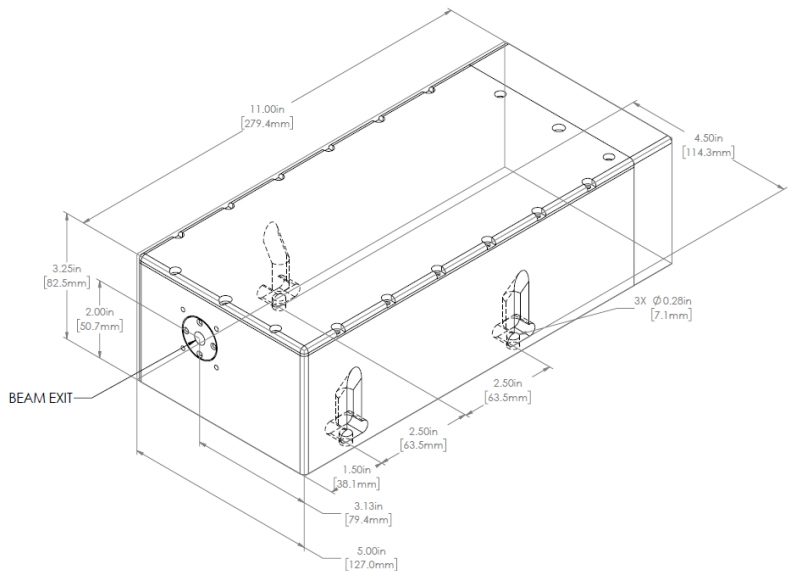
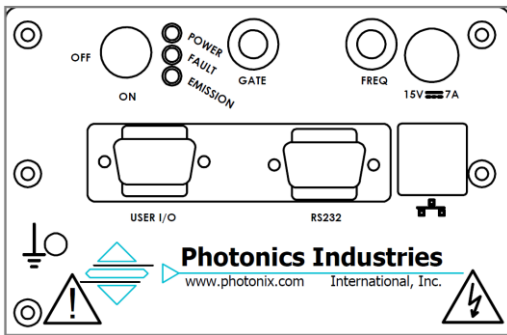
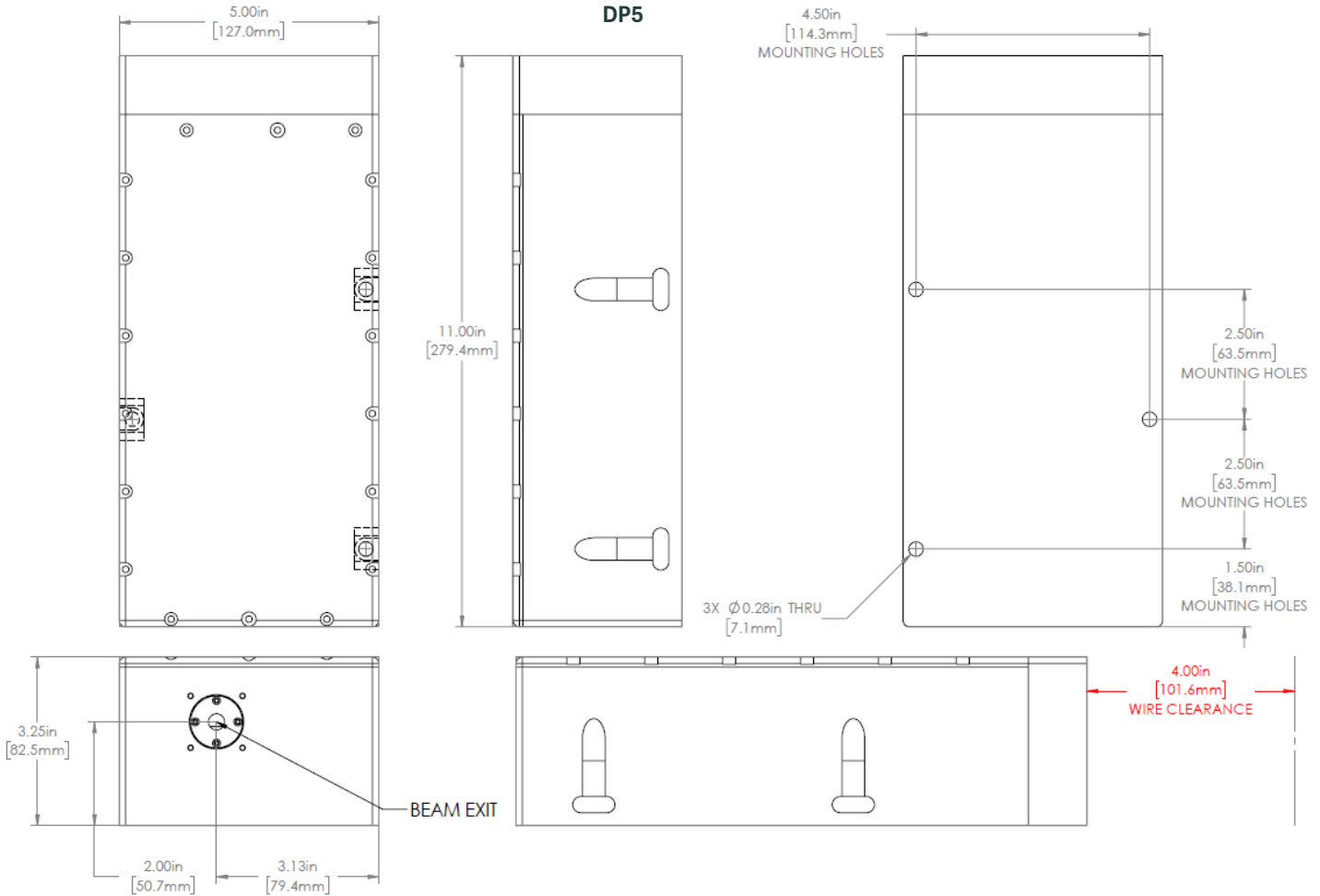

Our ongoing policy is to improve the design and specification of our products. The information provided is non-binding.

© 2025 Photonics Industries International, Inc.

Headquarters: 1800 Ocean Ave, Ronkonkoma, New York 11779, United States

Photonics Industries International Inc. is the pioneer of intracavity harmonic lasers and is at the forefront of developing, manufacturing, and marketing a wide range of nanosecond, sub-nanosecond, picosecond, and femtosecond lasers for the industrial, scientific, defense and medical industries.

For more information www.photonix.com



Dimensional Drawings
DP1k, DP50

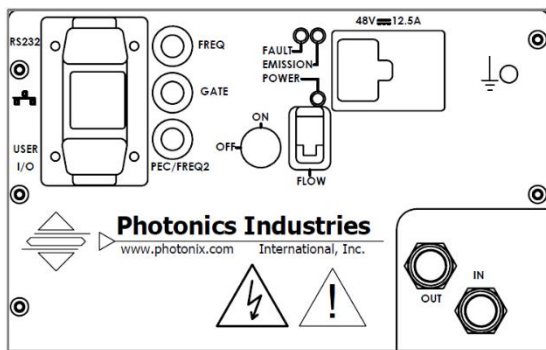
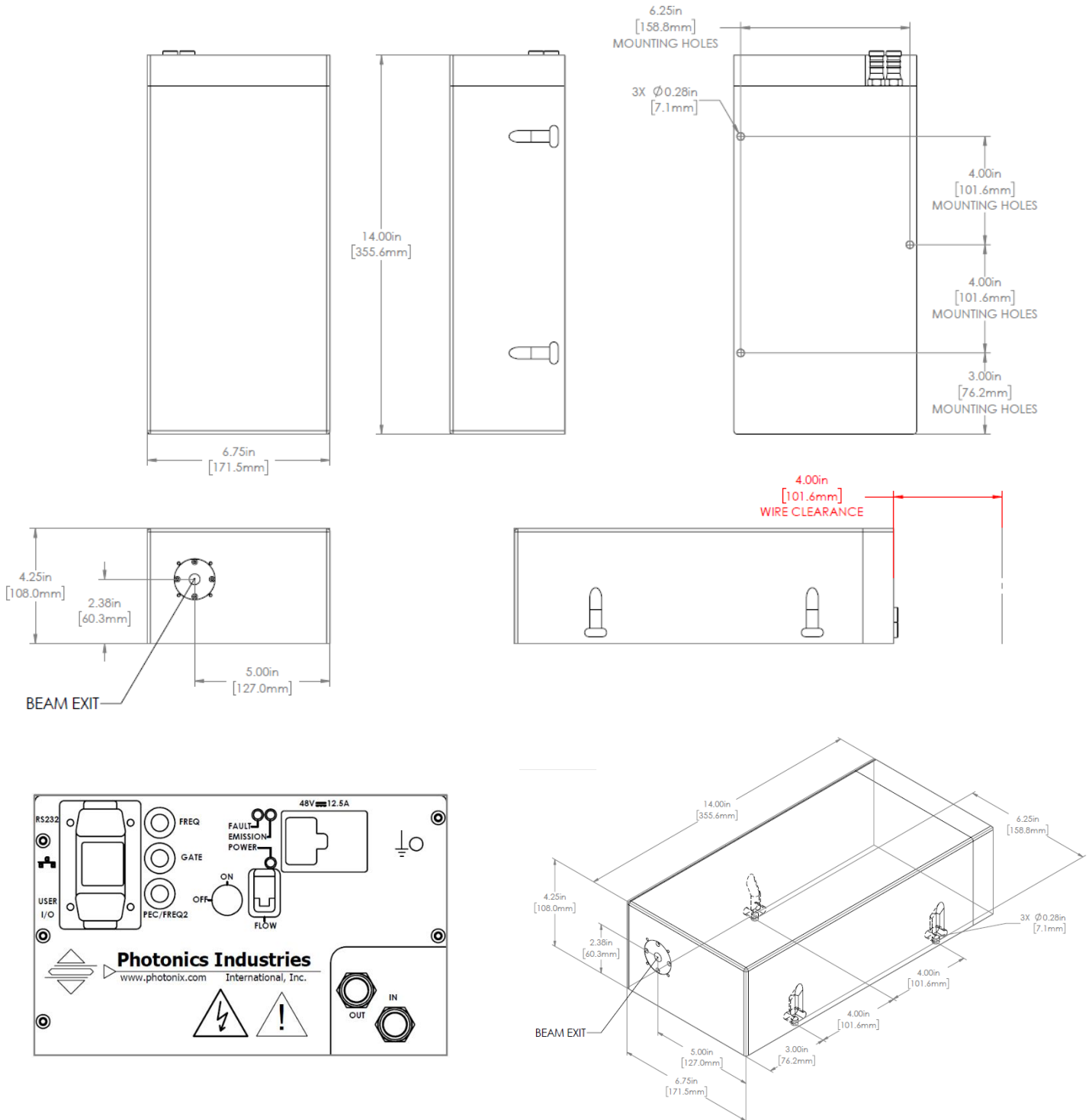

Our ongoing policy is to improve the design and specification of our products. The information provided is non-binding.

© 2025 Photonics Industries International, Inc.

Headquarters: 1800 Ocean Ave, Ronkonkoma, New York 11779, United States

Photonics Industries International Inc. is the pioneer of intracavity harmonic lasers and is at the forefront of developing, manufacturing, and marketing a wide range of nanosecond, sub-nanosecond, picosecond, and femtosecond lasers for the industrial, scientific, defense and medical industries.

For more information www.photonix.com



Dimensional Drawings

DP20

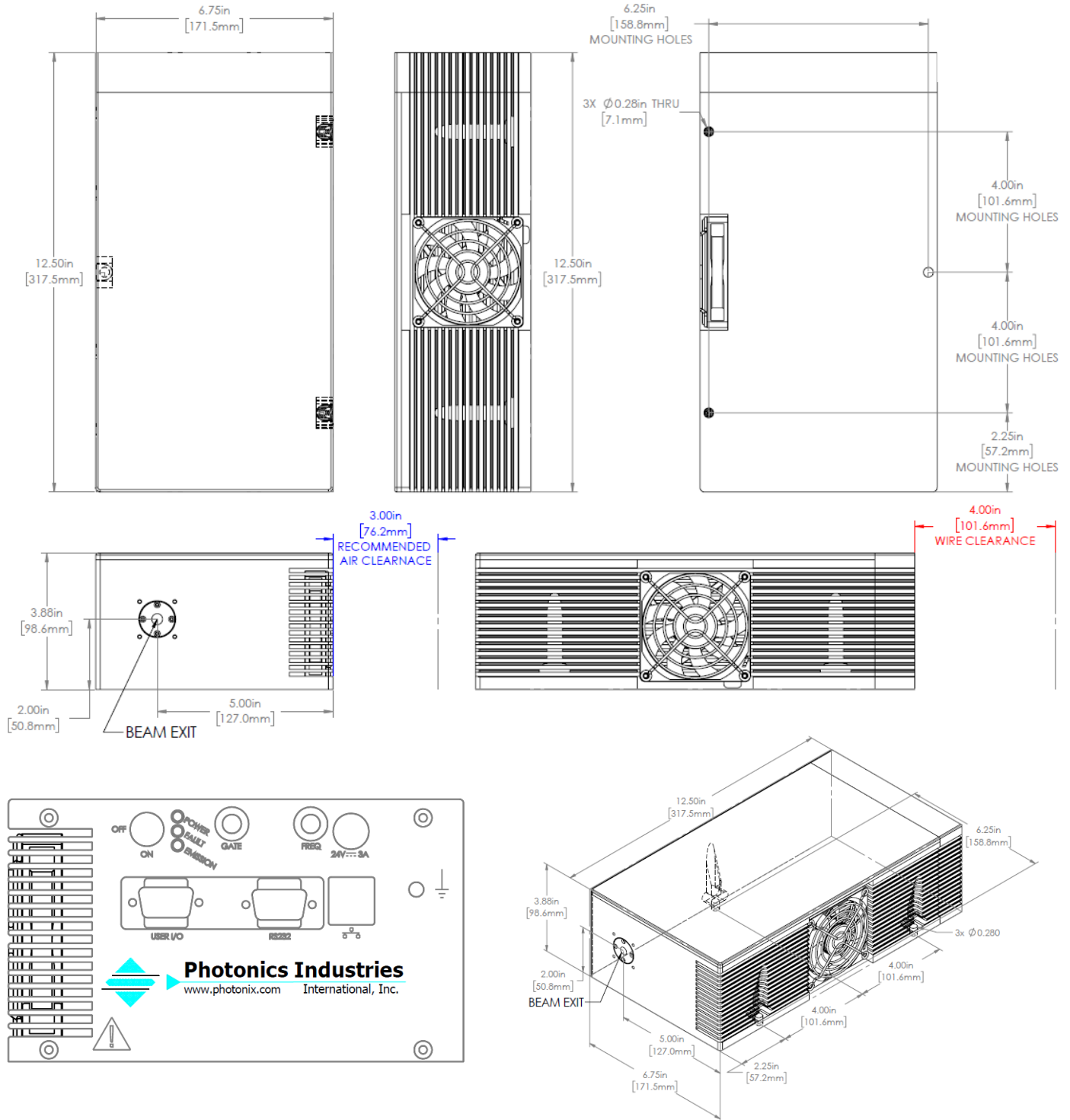

Photonics Industries
www.photonix.com International, Inc.



Our ongoing policy is to improve the design and specification of our products. The information provided is non-binding.

© 2025 Photonics Industries International, Inc.

Headquarters: 1800 Ocean Ave, Ronkonkoma, New York 11779, United States

Photonics Industries International Inc. is the pioneer of intracavity harmonic lasers and is at the forefront of developing, manufacturing, and marketing a wide range of nanosecond, sub-nanosecond, picosecond, and femtosecond lasers for the industrial, scientific, defense and medical industries.

For more information www.photonix.com



光と人をつなぐ

Rayture Systems



レイチャーシステムズ株式会社

〒160-0006 東京都新宿区舟町7 ロクサンビル7F

TEL : 03-3351-0717 FAX : 03-3351-6771

URL : <http://www.rayture-sys.co.jp>

E-mail : laser@rayture-sys.co.jp